

LOC	DIST	P	F	ZONE	LTR	REVISIONS	DATE	APPD
G	14					D REVISED PER 0720-0513-95	27MAR95	NRB

METRIC
 DIMENSIONS LISTED IN mm [INCHES]

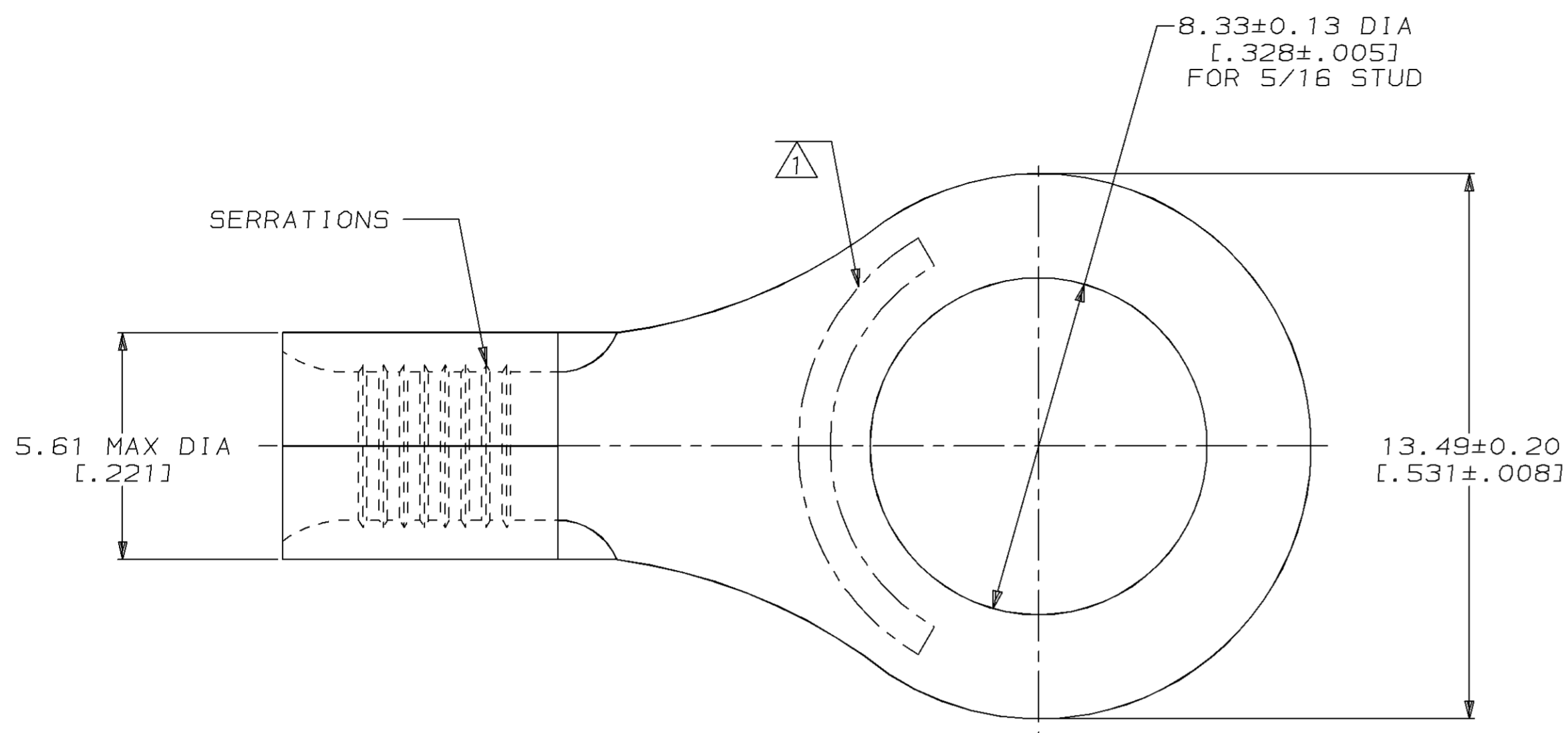

AMP WIRE RANGE	UL E13288 Listed
12-10 AWG STRANDED	12-10 AWG STRANDED
SR LR7189 Certified	MILITARY P/N AND CLASS
NOT CERTIFIED	NOT APPLICABLE

- 1 STAMP AMP 12-10* APPROX AS SHOWN
- 2 TIN PL 0.00254 [.000100] MIN THK PER MIL-T-10727
- 3 GOLD PLATE 0.00127 [.000050] MIN EXT THK PER MIL-G-45204 OVER NICKEL PLATE 0.00076 [.000030] MIN EXT THK PER QQ-C-290

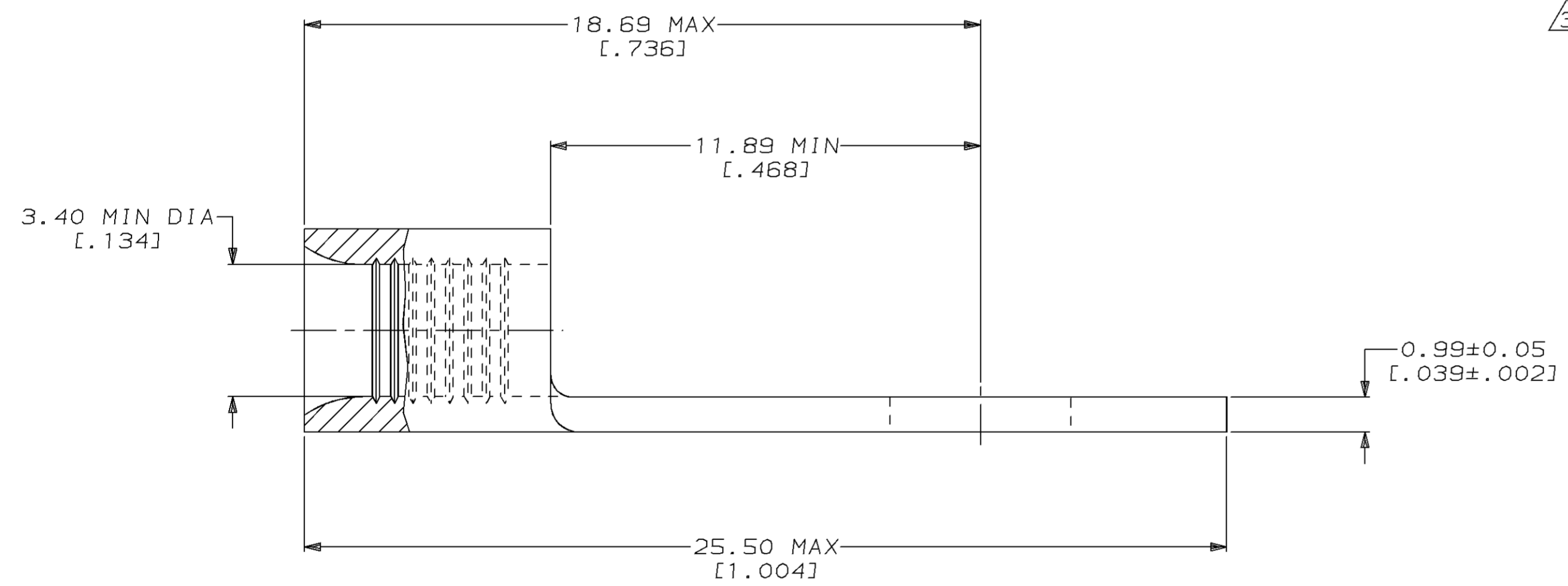

3	2-31123-2
2	31123
FINISH	PART NO

AMP INCORPORATED
CUSTOMER SERVICE SYSTEMS

FOR ADDITIONAL PRODUCT INFORMATION OR COPIES OF DRAWINGS AND TECHNICAL DOCUMENTS
 PRODUCT INFORMATION CENTER 1-800-522-6752

FOR APPLICATION TOOLING INFORMATION
 TOOLING ASSISTANCE CENTER 1-800-722-1111

FOR ORDER ENTRY
 1-800-526-5142

MAX RECOMMENDED OPERATING TEMPERATURE:
 170°C MAX

VOLTAGE RATING:
 NOT APPLICABLE

WIRE CROSS SECTIONAL AREA RANGE:
 2.62-6.64mm² [5,180-13,100] CIR MILS STRANDED

THIS DRAWING IS A CONTROLLED DOCUMENT FOR AMP INCORPORATED. IT IS SUBJECT TO CHANGE AND THE CONTROLLING ENGINEERING ORGANIZATION SHOULD BE CONTACTED FOR THE LATEST REVISION.

DO NOT SCALE PRINT. UNLESS SPECIFIED DIMENSIONS IN mm [INCHES] - TOLERANCES ON :

2 PLC DEC ± -
 3 PLC DEC ± -
 ANGLES ± -

MATERIAL
 COPPER PER ASTM B-152 ANNEALED

FINISH
 SEE TABLE

DR 2-9-93 TA BRINKMAN
 CHK 2-9-93 DA PATTERSON
 APPD 2-9-93 DE MILLER
 APPD 2-9-93 JL MECKLEY
 PRODUCT SPEC -
 APPLICATION SPEC -
 WEIGHT -

AMP AMP Incorporated
 Harrisburg, PA 17105-3608

NAME
TERMINAL, RING TONGUE, BUDGET

SIZE CAGE CODE DRAWING NO
 C 00779 C=31123

SCALE 8:1 SHEET 1 OF 1